

Thermostable farnesyl diphosphate synthase of *Bacillus stearothermophilus*: crystallization and site-directed mutagenesis

Tanetoshi Koyama¹, Shusei Obata³, Masami Osabe², Kazuhiro Saito¹,
Ayumi Takeshita³, Tokuzo Nishino² and Kyozo Ogura^{1*}

¹Institute for Chemical Reaction Science, ²Department of Biochemistry and Engineering,
Tohoku University, Sendai 980, Japan, ³Bio Research Laboratory, Research Division,
Toyota Motor Corp., Toyota, Aichi 471, Japan

Key words: prenyltransferase, farnesyl diphosphate synthase, site-directed mutagenesis

The gene for thermostable farnesyl diphosphate synthase from *Bacillus stearothermophilus* was cloned, sequenced, and overexpressed in *Escherichia coli*. The synthase was purified to homogeneity and crystallized. The enzyme carried only two cysteine residues in contrast to its counterparts from other sources, which have four to six cysteine residues. Either or both of the cysteine residues can be replaced with serine without causing a loss of the catalytic activity. The conserved arginine residue that occupies the third position from the C-terminus was also replaced with valine without significant loss of activity, but the valine mutant showed a weakened affinity for isopentenyl diphosphate.

Farnesyl diphosphate (FPP)¹ synthase (EC 2.5.1.10) one of the prenyltransferases, occupies the central point of prenyl chain elongation process in isoprenoid biosynthesis. It catalyzes

the condensation of IPP with DMAPP and with GPP to give FPP as the ultimate product (Scheme 1). Recently, cDNAs or genomic clones encoding FPP synthase have been isolated from

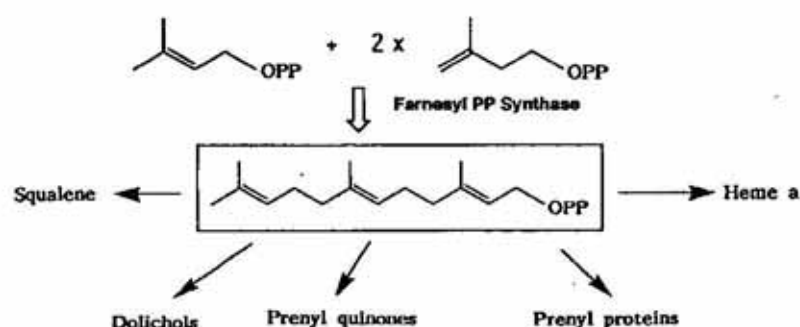

Scheme 1. The role of farnesyl PP synthase in isoprenoid metabolism.

*To whom correspondence should be addressed.

¹The abbreviations used in this paper are: bp, base-pair; DMAPP, dimethylallyl diphosphate; FPP, farnesyl diphosphate; FPS, farnesyl diphosphate synthase gene; GGPP, geranylgeranyl diphosphate; GPP, geranyl diphosphate; HPP, hexaprenyl diphosphate; IPP, isopentenyl diphosphate; IPTG, isopropyl-1-thio- β -D-galactopyranoside; PCMB, *p*-chloromercuribenzoic acid; SDS-PAGE, sodium dodecylsulphate polyacrylamide gel electrophoresis.

various eukaryotes including rat, yeast, and humans, and their nucleotide sequences have been determined and compared [1–3]. For prokaryotic FPP synthase, however, only the gene from *E. coli* has been cloned and sequenced [4]. Therefore, no comparative information between prokaryotic enzymes is available.

Prenyltransferases are extremely interesting in that they catalyze the repetition of stereospecific condensation of IPP with prenyl diphosphates to give products of definite chain length and stereochemistry, which determine the specificity of individual enzymes.

In order to extend the comparative studies on prenyltransferase structures, and also to obtain large quantities of a stable prenyltransferase preparation required for further studies including enzymological and X-ray crystallographic approaches, we isolated and sequenced the gene for FPP synthase from a thermophilic bacterium, *Bacillus stearothermophilus*. We also succeeded in overproduction of this thermostable enzyme and its crystallization.

Furthermore we conducted site-directed mutagenesis studies to explore the role of several amino-acid residues.

MATERIALS AND METHODS

Materials

[1-¹⁴C]Isopentenyl diphosphate (1.95 GBq/mol) was purchased from Amersham (England). Restriction enzymes and DNA-modifying enzymes were purchased from Takara Shuzo (Japan). *B. stearothermophilus* ATCC 10149 was used as the source of chromosomal DNA. *E. coli* K12 strain JM109 was used as the host for the *B. stearothermophilus* DNA library.

Construction of expression vector systems

Construction of expression vector system for FPP synthase. To subclone the FPP synthase gene into an expression vector, oligonucleotide-mediated mutagenesis was carried out to create new restriction sites, *Nco*I- and *Hind*III-sites, just before and after the open reading frame of the FPP synthase gene, respectively.

Two oligonucleotides of 30 bases each, 5'-GAGGAGGAGTAAGCCATGGCGCAGCTT-TCA-3' and 5'-CGACCATTAAAAGCTTAA-CGCCCGCCCTTG-3', were synthesized to direct the mutation that was to create the *Nco*I-

and *Hind*III restriction sites immediately upstream of the translation-initiation codon, GTG, and 5-bp downstream of the termination codon, TAA, respectively. After introduction of the new *Nco*I- and *Hind*III-sites, the *Nco*I-*Hind*III gene fragment of pΔ1a encoding the FPP synthase gene was ligated into *Nco*I-*Hind*III-site of pTrc99A (Pharmacia) to construct a recombinant plasmid, pEX11 (Fig. 1).

Purification of the cloned FPP synthase. *E. coli* JM105 cells (30 g) harboring pEX11 were harvested from a 10-l culture in M9YG medium by centrifugation. The cells were suspended in 90 ml of 25 mM Tris/HCl buffer, pH 7.7, containing 1 mM EDTA, 10 mM 2-mercaptoethanol, 0.1 mM phenylmethylsulfonyl fluoride and 10 μg phosphoramidon. The cells were then homogenized at 0°C for 30 min with Vibrogen Cell Mill (Edmund Bühler) using 180 ml of glass beads (0.1 mm in diameter). After removal of the glass beads by filtration, the filtrate was centrifuged at 100 000 × g for 30 min. The supernatant was heated at 60°C for 60 min and then centrifuged at 100 000 × g for 30 min. The protein fraction precipitated from the supernatant at 0.35–0.75 ammonium sulfate saturation was dialyzed against 25 mM Tris/HCl buffer, pH 7.7, containing 10 mM 2-mercaptoethanol, and chromatographed on a Butyl-Toyopearl 650M column (5.0 cm × 45 cm) equilibrated with 25 mM Tris/HCl buffer, pH 7.7, containing 10 mM 2-mercaptoethanol and ammonium sulfate at 0.35 saturation. Elution was performed with a decreasing linear gradient from 0.35 to 0 ammonium sulfate saturation in 25 mM Tris/HCl buffer, pH 7.7, containing 10 mM 2-mercaptoethanol. FPP synthase fractions were collected and then applied to a Mono-Q column (10 mm × 100 mm) equilibrated with 25 mM Tris/HCl buffer, pH 7.7, containing 10 mM 2-mercaptoethanol and 1 mM EDTA. Elution was performed with linear gradient of 0–0.5 M NaCl. The FPP synthase fractions were applied for purity by SDS-PAGE (14%) by Coomassie Brilliant Blue staining.

Amino-acid sequence analysis was carried out with a protein sequencer (Applied Biosystems, Model 473A).

Site-directed mutagenesis. To introduce mutations in the structural gene for the FPP synthase of *B. stearothermophilus*, a *Bam*HI/*Hind*III DNA fragment from the clone pΔ1a [5] was subcloned into pTZ18R (Toyobo) yielding

pEX47. Then single-stranded DNA templates were isolated with the use of a helper phage, M13K07. Site-directed mutagenesis was conducted with uracil-enriched single-stranded DNA, and a series of mutated plasmids, pMu18, pMu88, and pMu84, were obtained. The introduction of mutation was confirmed by sequencing the whole nucleotide sequence using the dideoxy chain-termination method with a DNA sequencer (Applied Biosystems, model 373A).

RESULTS AND DISCUSSION

Molecular cloning and sequencing

Total DNA isolated from *B. stearothermophilus* was subjected to partial digestion with *Sau3A*I, and the 2–5 kbp fragments were ligated into the

*Bam*HI site of vector pUC118. The recombinant plasmids were then transformed into *E. coli* JM109, and the transformants were screened for expression of prenyltransferase genes by taking advantage of the fact that the enzyme of this thermophilic bacterium is much more stable than those of the host *E. coli*. As a result of screening five thousand colonies, one active clone producing a thermostable prenyltransferase was obtained. The clone was found to carry a 5 kbp *Sau3A*I insert containing the gene for FPP synthase. Further analyses of various regions subcloned from the 5 kbp fragment located the gene within a 2.0 kbp *Pst*I–*Nru*I restriction fragment (Fig. 1).

Sequence analysis of the 2.0 kbp fragment revealed an open reading frame that encodes a predicted protein of 297 amino acids with an M_r of 32309 and GTG as the initiation codon.

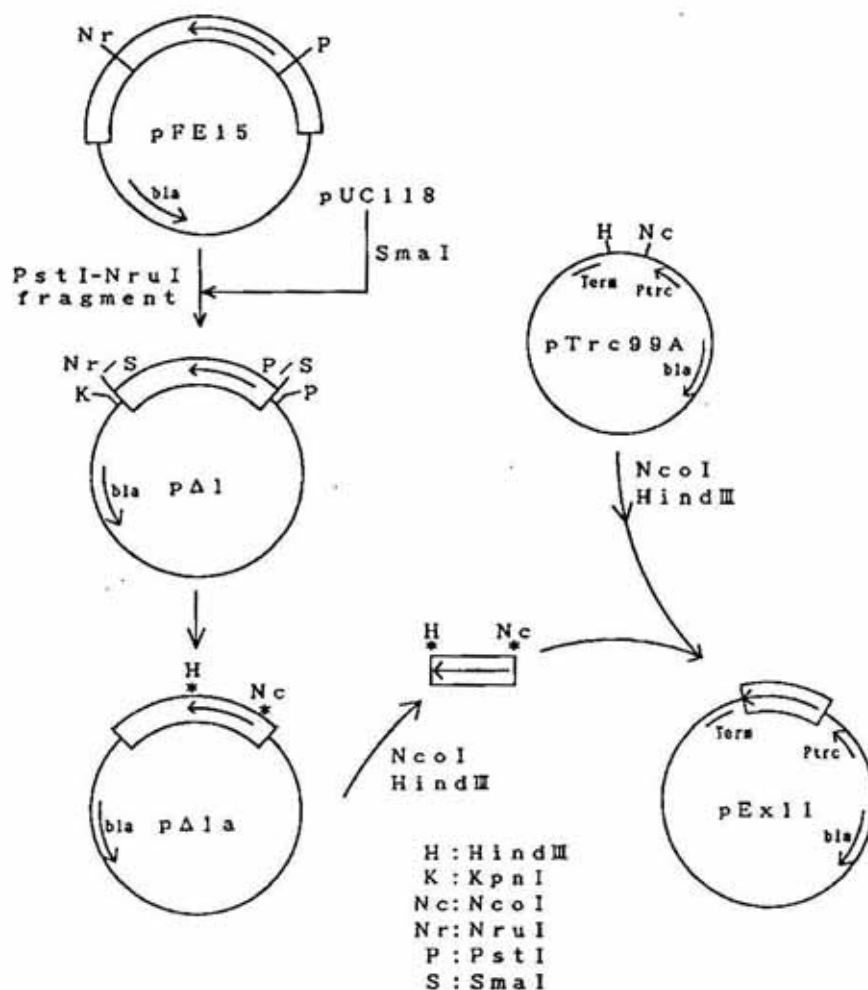

Fig. 1. Schematic diagram of construction of the plasmid.

Restriction sites; H, *Hind*III; K, *Kpn*I; Nr, *Nru*I; P, *Pst*I; S, *Sma*I; Nc, *Nco*I. The arrow indicates the coding region of the FPP synthase and asterisks on the arrow indicate the point-mutated sites.

Overproduction and purification

An overexpression plasmid for the FPP synthase was constructed by inserting an open reading frame cassette having ATG, instead GTG, as the initiation codon into an expression vector, pTrc99A, which carries the strong hybrid promoter (*trc*) inducible with IPTG (Fig. 1). The thermostable FPP synthase produced by *E. coli* JM105 cells transformed with this plasmid constituted about 20% of the total protein. Because of its stability and abundance, the cloned enzyme was easily purified to homogeneity in several steps including heat treatment and two chromatographic procedures (Fig. 2). As expected, the electrophoretically homogeneous enzyme showed a satisfactory stability.

The recombinant enzyme was confirmed to be immunochemically identical with the enzyme of *B. stearothermophilus* (not shown). In addition, amino acid analysis showed that 10 residues in the N-terminal region of the recombinant protein were identical with those deduced from the nucleotide sequence.

Crystallization

To 50 µg protein dissolved in 50 mM phosphate buffer (pH 5.2, final volume 5 µl) was added 2–3 µl of 30% polyethylene glycol or 2–3 µl of a saturated ammonium sulfate solution, and the solution was vapor-equilibrated with a reservoir solution containing 50 mM phosphate buffer. When this was left standing at 4°C for a week, square-bipyramidal crystals appeared as shown in Fig. 3.

Comparison of amino-acid sequences

In the bacterial FPP synthase from *B. stearothermophilus* and *E. coli* [4], 42% of the amino acids were identical. Comparison with FPP synthases of eukaryotes, including human, rat and *S. cerevisiae* enzymes [1–3], shows 22% to 24% sequence similarities. Furthermore, the sequence of *B. stearothermophilus* enzyme shows 24% and 23% similarities with those of other prenyltransferases, geranylgeranyl diphosphate synthase *N. crassa* [6] and hexaprenyl diphosphate synthase of yeast [7], respectively. As shown in Fig. 4, there are seven regions which show significant similarities. The relative positions of the homologous regions, designated as regions A to G, are nearly the same in all FPP synthases derived from proka-

ryotic and eukaryotic cells, but the N-terminal regions of GGPP- and HPP-synthases are longer by about 100 amino-acid residues than those of FPP synthases (Fig. 5). Among the seven regions, regions B and F are best conserved and characterized by the presence of aspartate-rich sequences which have been termed domains I and III by Carattoli *et al.* [6] or domains I and II by Ashby & Edwards [7]. The DDXXD motif may serve as binding sites for the diphosphate groups of the substrates by forming magnesium salt bridges as assumed by

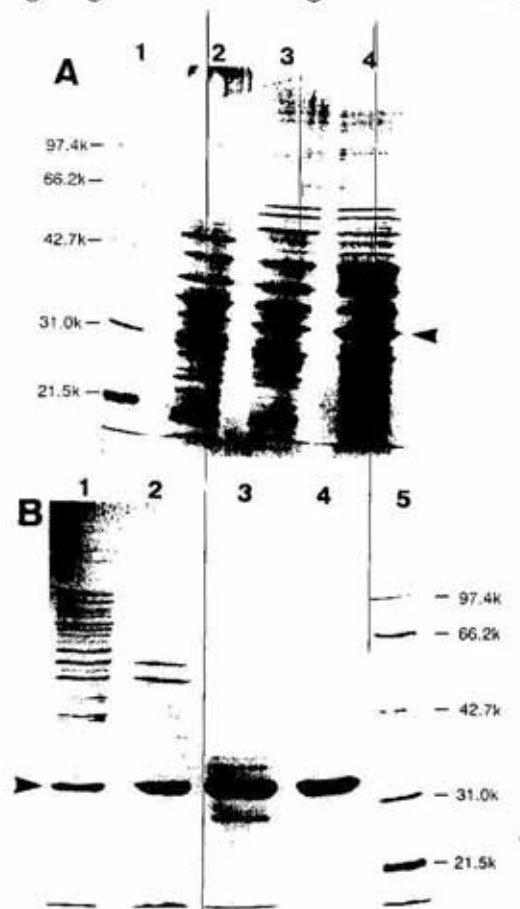

Fig. 2. SDS-PAGE analyses of overproduction (A) and purification (B) of FPP synthase from *E. coli* cells harboring pEX11.

(A) Total protein extracts from *E. coli* JM105. Lane 1, molecular mass markers (in kDa); lane 2, *E. coli* JM105 without pEX11; lane 3, *E. coli* JM105 with pEX11 without addition of IPTG; lane 4, *E. coli* JM105 with pEX11 after induction with IPTG. (B) Purification of FPP synthase. Lane 1, 100000 × *g* supernatant of the cell homogenate; lane 2, after heat treatment at 60°C for 60 min; lane 3, after Butyl-Toyopearl chromatography; lane 4, after Mono-Q chromatography; lane 5, molecular mass markers: soybean trypsin inhibitor (21.5 kDa), bovine carbonic dehydrase (31.0 kDa), bovine muscle actin (42.7 kDa), bovine serum albumin (66.2 kDa), rabbit muscle phosphorylase B (97.4 kDa). Arrowheads indicate the location of FPP synthase.



Fig. 3. Crystals of *B. stearothermophilus* FPP synthase.

Ashby & Edwards [7]. They have suggested that domain II (corresponding to region F in this report) comprises the allylic diphosphate binding site [8]. Our preliminary experiments on site-directed mutagenesis of this thermostable FPP synthase indicate that the conserved aspartic acids at 86, 87 and 92 in region B and at 224 and 225 in region F are all critical for the enzymatic activity (data not shown).

The eukaryotic FPP synthases contain sequences similar to that of the region proposed to be the active site of avian FPP synthase [9] but, interestingly, such sequences have not been found in the bacterial enzymes. In the *B. stearothermophilus* FPP synthase some of the amino-acid residues, fully conserved in other FPP synthases, are replaced by functionally different residues, cysteine, alanine, leucine, glutamine, and lysine, being replaced by asparagine-103, glycine-118, methionine-164, arginine-223 and histidine-297 (C-terminal), respectively.

It is also noteworthy that the thermostable FPP synthase possesses only two cysteine residues, while the other enzymes have four to six cysteines. In FPP synthases two cysteines are conserved within region B except in the thermostable enzyme, in which one of the con-

served cysteine residues is replaced by asparagine-103.

Ashby & Edwards [7] have noted that the C-terminal region is also conserved and is rich in basic amino acids. In the FPP synthase of *B. stearothermophilus*, however, only two out of thirteen amino acids in this region are conserved. In addition, there are two basic and two acidic amino acids in this region.

Effect of substitution for the three carboxyl-terminal amino acids

Site-directed mutagenesis studies carried out by Marrero *et al.* [9] using rat FPP synthase have been recently shown that one of the highly conserved aspartate residues in domain II (region F in this report) is essential for catalytic function while another can be replaced with glutamate without significant change in catalytic properties. However, the significance of the highly conserved arginine residues remains unknown, though prenyltransferases have been shown to be sensitive to arginine-specific reagents. Among the seven conserved regions in FPP synthases there are four highly conserved arginines in regions A, B (two residues) and G. We conducted site-directed mutagenesis studies, using the FPP synthase of *B. stearothermophilus*, in attempt to explore the role of the conserved arginine residue that occupies the third position from the carboxyl terminus. We also investigated the effects of mutagenesis in the penultimate and the carboxyl terminus residues.

Figure 6 shows the C-terminal sequences of *B. stearothermophilus* FPP synthase and its mutated enzymes along with the sequences of mutagenic oligonucleotides.

The arginine residue at position 295, which is completely conserved in region G, was changed to valine to produce a less basic mutant (R295V). The aspartic acid at 296 was replaced with glycine to make the C-terminal region less acidic (D296G). Substitution of leucine for the histidine at the C-terminus was carried out to make the C-terminal region less basic (H297L).

To construct overexpression systems for these mutants, we employed plasmid pΔ1a, in which *Nco*I- and *Hind*III-sites were introduced immediately upstream and downstream of the open reading frame of this FPP synthase gene, respectively. The *Bam*HI/*Hind*III DNA fragment

(6) MAVTSSSPGAPLGLSLSNDDFAPFNINTKFSAIVPPTS SQPISVAIP SNRISAGLAQAQQOAKRKAQVAQISLP SMLP TFSFSPYT
 (7) MFQRSGAARHIKLISSRCRCKSFVAALNAKLVTKILNRNPI SLVSKEMNTLAKNIVALIGSGHPVLNKVTSYFFETEGCKKVRPLLVLLLSRALSEIPMTBRNH

(1)	MA	QLSVEQFLNEQQAQVET	ALSRYIERL	EG	PAK	L	K	KAM	A	YSLEAGGKRTRPL	LL	LS	TVRAL	GKDPVAVGLPVA	CAI	EMHIT	
(2)	MDFP	-QLEACY	---NQ	----F-AP-	PFON	T	PVVEI	-Q	-CALL	----L--F	-V	YA	-GHMF	-VSTNLOADP-AAVE	-	-A	
(3)	M-SEK	IRRRER	FLNVPKLVSE	-NASLLAYGMPREACDHYAHS	LN	NTP	---LN-G-	SVVDYAI	--NK--EQ-	-OEVEYKVAILGM	-	-	-LLQ	A	-	-LLQ	
(4)	MNGD	-N-D	VYAOE	--DFVQH	-QIVRV	-TEDEMGH	-EIGDAIARL	-EV	LE	-NAI	---YN-G-	TVWAFRE	-VEPRK	QDADSLORAWT	VGM	-V-LLQ	
(5)	MNGD	-KLD	VHNOE	--DFIQHF	-QIVKV	-TEDELGH	-EGDAITRI	-EV	LE	-NTV	---YN-G-	IIVQTFQE	-VEPRK	QDADSLORAWT	VGM	-V-LLQ	
(6)	M- P-		P-PPNPDRF	FATEDFFSPSRRTWSEKKEKVLGTPYD	VK	-LNGHP	-D--SQ	MVKAFDAM	-D	VP	SESL	-IT	KV	-SHL	--A		
(7)	LKIDKSD	-PEDPIYS	-PSQNQLFORPASSIS		L	H	ILH	-I	PLM	--	TKGPEP	-PEE	-FDKQR	-IL	-KQRRL	AE	-V

(1)	YSLIHDDLP	SHNDLRRGKPTN	H	KVF	GEAMAIL	A	GQG	LTYA	FQLITEIDD	ERIPSRVRLIERLAKAAGPEGMVA	QQAAHDH	EGEGKTLTISE										
(2)	---A	-D	-----L-C	-V	-F	---N	---	-ALQT-	-S	-LS	-ADMP	-VSDRDRISMIS-	-S-S	-IA	-CG	---	-L-L	DA	---HVP	-DA		
(3)	-F	-VA	-M	-KSIT	-Q	-C	WY	---	PEYGEI	-IN	-AF	M	E	A	-YLLKSHFRN	-KYYIDITELFH	-VTFQTEL	---	LM-L	ITAPEDKV	D	
(4)	FF	-VA	-I	---SSLT	-Q	-C	WYQ	-P	-VGLD	-IN	-AN	-E	E	C	-YRLKLYCR	-QPYL	NLI	-	-FLOSSYQTE	I	---	TL-L
(5)	FF	-VL	-I	---SSHT	-Q	-C	WYQ	-P	-IGLD	-IN	-AL	-E	A	-YRLKLYCR	-QPYL	NLI	-	-FLOSSYQTE	I	---	TL-L	
(6)	---LV	-	VE	-SV	---FPVA	-	SIFGIPQTINT	S	NYVYFYA	-QEL	OK	L	KPKAVSIF	-E	-LNLHR	---	GM-L	FWRD	TLTCP	---	GM-L	
(7)	---	-L	---	VI	-HS	-T	---	R	-SG	NAAFETNKMAVL	---	-	-F	---	-GR-	TVS	-SRL	HNPEV	-	LMNSIAN	-V	-GEFMQLKNTSI

(1)	LEYIHRH																					
(2)	---	R	---																			
(3)	-SK	FLKHKHSFIVTT																				
(4)	-V	FTKRYKSIVKY																				
(5)	-G	RYTEKRYKSIVKY																				
(6)	T	-DDYLEHVS																				
(7)	SKKLEVNEHDFRVP	SRQOGLQSHDQIETAFEYIHKTYL																				

(1)	OSNNKAT	Y	PAL	L	SLAGAK	EKLAFHTEA	AQRH	LRNADVDMGA													
(2)	-OLG	-S	---	---	LEQAR	-K	RDLDLD	-RQS	-KQLAEGSLOTSA												
(3)	I	-D	-CS	W	VINK	---ELASAEQRKT-	DENY	-K	-DSVAEKCKKIEND	-KIEQLYHEYESIAKDLKAKISQVDESRGFKADV											
(4)	I	-D	-CS	MLV	VQC	-ORATPEQYQI-	KENY	-Q	-A	EKVARVKALYEE	-DLPA	-FLQYEDSYSHIMALIEQYAAPLPPAVF									
(5)	I	-D	-CS	MLV	VQC	-ORATPEQYQI-	EENY	-Q	-DPEVARVKALYEE	-DLRS	-FLQYEDSYSHIMALIEQYAAPLPPAVF										
(6)	LTE	G	-FS	FPVIHSI	RSN	PSNHQ	-NILKOKT	-D	EEV	-RYAVAYMESTGSEYTRKIVKLVDRARQMTEDDGGKSGGIRKILDRIMLH											
(7)	LAL	GI	---	APVLFAM	KEDPSLGP	-ISRNF	-ER	-D	V	---TIDSVRLHNGIATKIL	-EEYRDKALQNLROSLPESDARSA										

Fig. 4. Comparison of conserved amino-acid regions of prenilyltransferases. FPP synthase from: 1, *B. stearothermophilus*; 2, *E. coli* [4]; 3, *S. cerevisiae* [2]; 4, humans [3]; 5, rat [11]; 6, GGPP synthase from *N. crassa* [6], and 7, HPP synthase from yeast [7]. The regions (A to G) which show significant sequence conservation are boxed. ---, Residues identical to the sequence of *B. stearothermophilus* FPP synthase. Asterisks indicate typical replaced residues in *B. stearothermophilus* FPP synthase (see text).

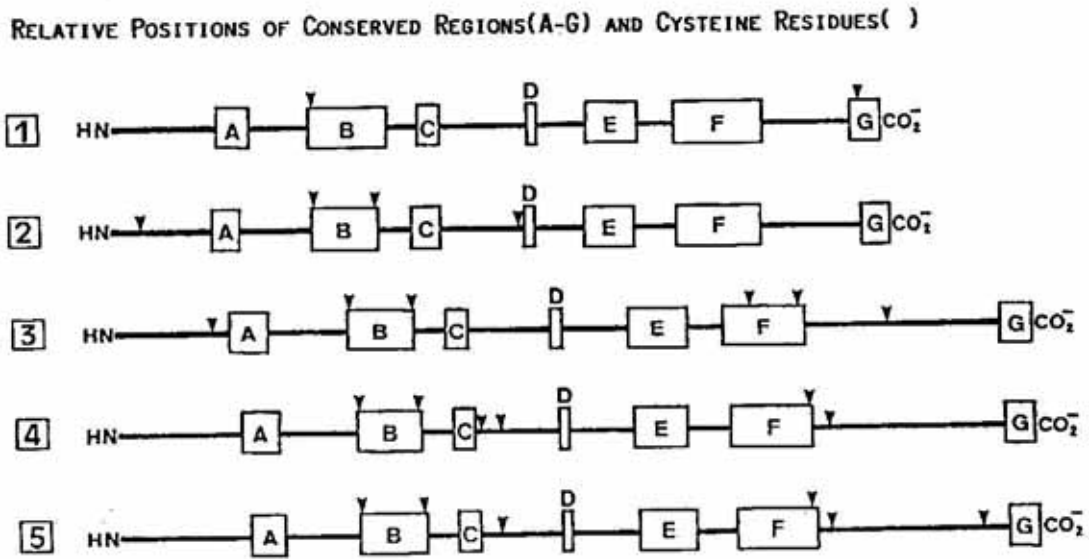

Fig. 5. Relative positions of the conserved regions (A to G) within each of the prenyltransferases. Notation of the prenyltransferases are the same as described for Fig. 4. The relative positions of each region within the enzymes are drawn to scale. Arrowheads indicate the location of cysteine residues.

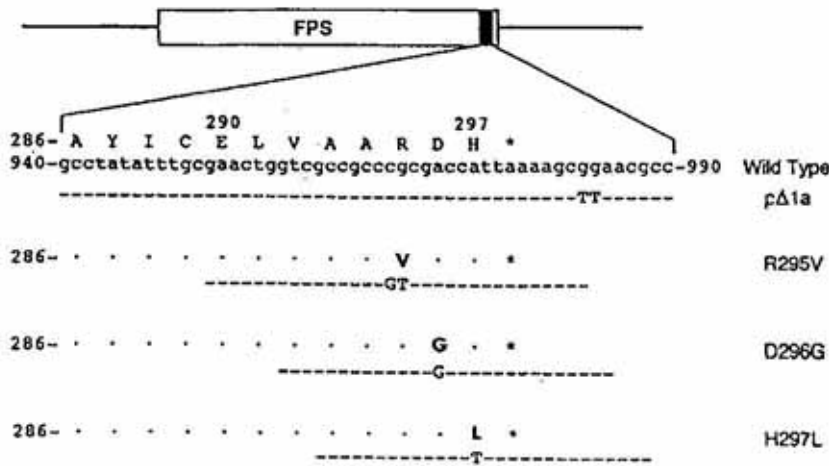

Fig. 6. Schematic presentation of wild-type and mutant gene sequences corresponding to region G. FPS stands for the farnesyl diphosphate synthase gene.

from pΔ1a was subcloned into pTZ18R and then oligonucleotide-mediated mutagenesis was conducted into the resulting plasmid, pEX47, to obtain a series of mutated plasmids, pMu18, pMu88, and pMu84 (Fig. 7).

The *NcoI/HindIII* fragment of each of the pMu plasmids was ligated into the *NcoI/HindIII* site of pTrc99A, and expression plasmids, pEX121, pEX125, and pEX134 were obtained.

After transformation of *E. coli* JM105 with these plasmids into the FPP synthase mutants, R295V, D296G, and H297L were overproduced and purified essentially according to the procedure described in this paper for the production of wild-type recombinant FPP synthase. This procedure yielded proteins that gave single bands on SDS-PAGE and their purity was esti-

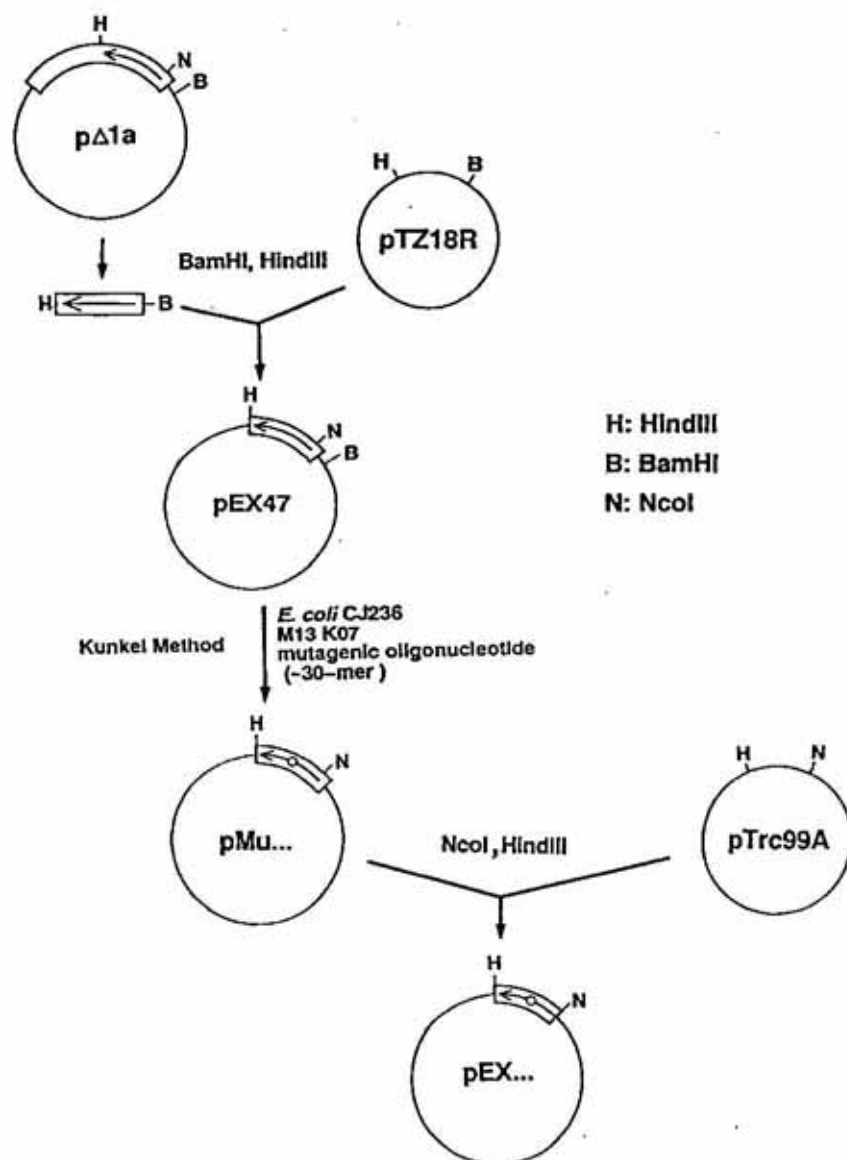

Fig. 7. Construction of the plasmids.

H, HindIII; B, BamHI; N, NcoI. The arrows indicate the coding region of FPP synthase and open circles on the arrow indicate the point-mutated sites.

mated to be better than 95% by staining with Coomassie Brilliant Blue (Fig. 8).

Kinetic parameters of the purified FPP synthase mutants are listed in Table 1. All the mutant enzymes showed sufficient catalytic activities comparable to that of the wild-type enzyme. H297L was even better than the wild-type in terms of specific activity and V_{max} . Even R295V, in which the highly conserved arginine had been replaced with valine, showed more than half the specific activity of the wild-type. The mutant enzymes showed similar pH-activity profiles to that of the wild-type enzyme, having pH optima about pH 8.0–8.5. The mu-

tant enzymes exhibited similar thermostability to that of the wild-type, retaining sufficient activity even after heating at 60°C for at least 50 min (not shown).

Product analysis revealed that (*all-E*)-farnesyl diphosphate was synthesized by all the mutant enzymes (not shown).

Thus it was found that none of the three amino-acid residues in the C-terminal region (region G) is essential for enzyme activity. It is noteworthy, however, that the K_m values of the mutated enzymes for IPP are approximately twice as large as that of the wild-type enzyme, while those for the allylic substrates, DMAPP

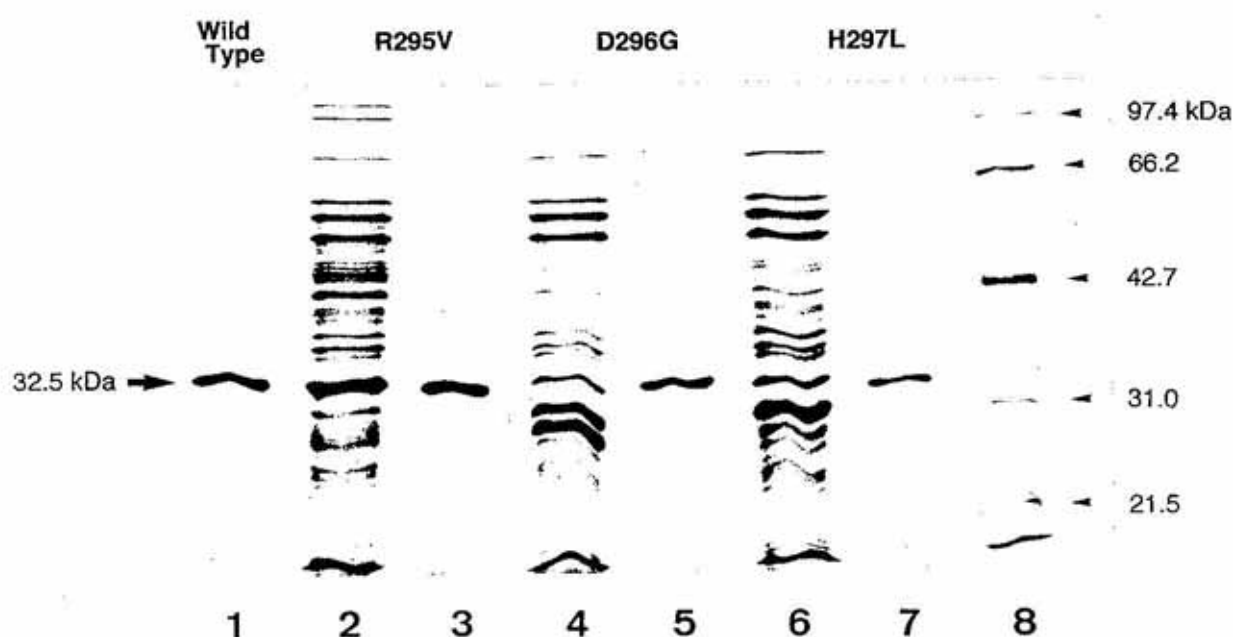

Fig. 8. Expression and purification of *B. stearothersophilus* FPP synthase and its mutants as monitored by SDS-PAGE.

Coomassie Brilliant Blue R stained 14% SDS-PAGE analysis showing the expression of wild-type FPP synthase and its mutants in *E. coli* (lanes 2, 4, and 6 show soluble extracts for R295V, D296G, and H297L, respectively). Lanes 1, 3, 5, and 7 show purified proteins obtained after Mono Q FPLC chromatography (lane 1, wild-type; lane 3, R295V; lane 5, D296G; lane 6, H297L). Lane 8, molecular mass markers.

and GPP, are similar to those found with the wild-type enzyme. These results suggest the possibility that the C-terminal region occupies a position that weakly affects the IPP binding site.

The specific activity of R295V is about half that of the wild type, while the other two mutants show values comparable to that of the wild type. Therefore, the arginine residue that is completely conserved at the third position

from the C-terminus seems to be more important for the enzymatic activity than the other two residues. The basic nature of the C-terminal region is also suggested by the observation that the replacement of the penultimate aspartate with glycine improved the V_{max}/K_m values for both DMAPP and GPP. However, it is surprising that the replacement of the C-terminal histidine with leucine is the most effective of the three in improving the enzymatic

Table 1

Kinetic parameters of mutant FPP synthases of B. stearothersophilus.

Each value represents the result obtained in a typical experiment. K_m is expressed as μM , V_{max} in nmol of $[1-^{14}\text{C}]\text{IPP}$ converted to FPP per minute per milligram of the enzyme.

Enzyme	Specific activity	DMAPP		GPP		IPP ^a		IPP ^b	
		K_m	V_{max}	K_m	V_{max}	K_m	V_{max}	K_m	V_{max}
Wild-type	1600	13.0	1750	6.4	3210	5.8	1080	14.3	3560
R295V	1070	16.6	867	6.2	1710	16.4	720	21.2	1560
D296G	1800	14.6	2940	5.1	2800	15.8	1990	19.6	3310
H297L	2140	11.0	1845	5.2	3260	15.3	2010	21.4	3810

^aFor the reaction with DMAPP. ^bFor the reaction with GPP.

activity with respect to both specific activity and the V_{\max}/K_m values for the allylic substrates.

It is interesting that the arginine residue conserved at the third position from the C-terminal is not essential for catalytic activity. However, this observation might not be surprising in view of the fact that the corresponding position is occupied by lysine and alanine in the GGPP synthase of *Neurospora crassa* [6], *Erwinia herbicola* [10] and of *Erwinia uredobora* [11].

One or both of the arginine residues forming the RRG motif in region B must be essential and responsible for the inhibition by arginine-specific reagents, because this motif is conserved not only in FPP synthases but also in GGPP synthases and HPP synthase.

According to the recent results of site-directed mutagenesis by Marrero *et al.* [9] in the aspartate-rich domain II, which is equivalent to region F of *B. stearothermophilus* FPP synthase, the first aspartate is involved in the catalysis by the enzyme. These authors found that when the first aspartate in domain II was replaced with glutamate, the K_m value for IPP increased 23-fold but that for GPP was unchanged. This tendency is somewhat similar to our result in that the K_m values of the mutant enzymes for IPP increased while those for allylic substrates did not change significantly. Namely, the binding affinity for IPP is affected more easily by amino acid substitution than that of the allylic substrates. Thus, the C-terminal region might

be located in such a space that affects the binding of IPP, though to a lesser extent than in the case of region F.

Effects of mutation at cysteine residues

It has been suggested that cysteine residues play important roles in the catalytic function of, or in the substrate binding by several prenyltransferases [12–14]. Moreover, there have been several reports on the multiple forms of FPP synthase from porcine liver [15–17] all of which are attributable to the oxidation-reduction behavior of cysteine residues of the enzymes.

Taking advantage of the fact that the *B. stearothermophilus* FPP synthase, unlike its counterparts from other sources, which have four to six cysteines, possesses only two cysteine residues, we studied the effect of mutation at these residues in this thermophilic synthase.

The cysteine residue at position 73, which is fully conserved in region B, was changed to phenylalanine or serine to produce C73F or C73S, respectively. The cysteine residue at position 289 was also replaced with phenylalanine or serine to produce C289 or C289S, respectively. A mutant enzyme (C73S-C289S) in which both 73- and 289-cysteine residues were replaced with serine, was also constructed by connecting the mutated gene fragments derived from those of C73S and of C289S.

All of the five mutant enzymes obtained showed prenyltransferase activity, indicating

Table 2

Kinetic parameters of the wild-type and mutant enzymes of B. stearothermophilus.

Each value represents the mean of 2 determinations. K_m is expressed as μM , V_{\max} in nmol of [$1\text{-}^{14}\text{C}$]IPP converted to FPP per minute per milligram of the enzyme.

Enzyme	Specific activity	GPP		IPP ^a	
		K_m	V_{\max}	K_m	V_{\max}
45°C ^b					
Wild-type	2610	5.8	4270	4.7	3410
C73F	1300	4.9	2650	4.8	2020
55°C					
Wild-type	4690	8.4	7330	13.0	7200
C289F	350	7.5	2630	130	2760
C73S	4300	7.3	9810	11.6	7850
C289S	3940	6.4	9330	14.3	9170
C73S-C289S	3970	5.6	7810	13.3	7540

^aFor the reaction with GPP. ^bAs C73F loses its activity at 55°C, kinetic data at 45°C were obtained.

that neither the cysteine residues at position 73 nor at 289 is essential for the enzyme catalytic function. Table 2 shows kinetic parameters of the purified mutants along with those of the wild-type enzyme. The mutant enzymes having replacement with serine, C73S, C289S, and C73S-C289S, showed specific activities comparable to that of the wild-type enzyme. However, the specific activities of the mutants having phenylalanine in place of cysteine, C73F and C289F, were approximately half and one thirteenth that of the wild-type enzyme, as assayed at 45°C and 55°C, respectively.

Although the K_m values of the mutant enzymes for GPP are all similar to that of the wild-type, the K_m value of C289F for IPP is approximately 10 times that of the wild-type (Table 2).

These facts suggest that the binding affinity for IPP is affected by the replacement of cysteine-289 with phenylalanine. It is likely that the C-terminal region (region G) containing cysteine-289 is located in a space that affects the binding of IPP. This conclusion coincides with the results obtained in our above mentioned site-directed mutagenesis studies focused on the three C-terminal amino acids of this enzyme.

It is noteworthy that cysteine-73, which is completely conserved in region B of all the FPP synthases from various organisms, is not important for the binding of IPP, though it seems to be involved in the stabilization of the enzyme. The inhibitory effect observed at rather high concentrations of PCMB (not shown) seems to be attributable to a conformational change of the enzyme protein (not shown). Probably, the SH reagent inactivates the enzyme by modifying both cysteine residues with such bulky groups that the conformation of the enzyme protein is largely affected, rather than by causing a loss of the function of sulfhydryl groups.

C73F lost most of its enzymatic activity after heat treatment while that of the other mutants, C73S, C289F, C289S, and C73S-C289S remained as stable as in the wild-type enzyme.

REFERENCES

1. Clerke, C.F., Tanaka, R.D., Svenson, K., Wamsley, M., Fogelman, A.M. & Edwards, P.A.

- (1987) Molecular cloning and sequence of a cholesterol-repressible enzyme related to prenyltransferase in the isoprene biosynthetic pathway. *Mol. Cell. Biol.* 7, 3138–3146.
2. Anderson, M.S., Yarger, J.G., Burck, C.L. & Poulter, C.D. (1989) Farnesyl diphosphate synthetase. Molecular cloning, sequence, and expression of an essential gene from *Saccharomyces cerevisiae*. *J. Biol. Chem.* 264, 19176–19184.
3. Wilkin, D.J., Kutsunai, S.Y. & Edwards, P.A. (1990) Isolation and sequence of the human farnesyl pyrophosphate synthetase cDNA. Coordinate regulation of the mRNAs for farnesyl pyrophosphate synthetase, 3-hydroxy-3-methylglutaryl coenzyme A reductase, and 3-hydroxy-3-methylglutaryl coenzyme A synthase by phorbol ester. *J. Biol. Chem.* 265, 4607–4614.
4. Fujisaki, S., Hara, H., Nishimura, Y., Horiuchi, K. & Nishino, T. (1990) Cloning and nucleotide sequence of the *isp A* gene responsible for farnesyl diphosphate synthase activity in *Escherichia coli*. *J. Biochem. (Tokyo)* 108, 995–1000.
5. Marrero, P.F., Poulter, C.D. & Edwards, P.A. (1992) Effects of site-directed mutagenesis of the highly conserved aspartate residues in Domain II of farnesyl diphosphate synthase activity. *J. Biol. Chem.* 267, 21873–21878.
6. Carattoli, A., Romano, N., Ballario, P., Morelli, G. & Macino, G. (1991) The *Neurospora crassa* carotenoid biosynthetic gene (Albino 3) reveals highly conserved regions among prenyltransferases. *J. Biol. Chem.* 266, 5854–5859.
7. Ashby, M.N. & Edwards, P.A. (1990) Elucidation of the deficiency in two yeast coenzyme Q mutants. *J. Biol. Chem.* 265, 13157–13164.
8. Ashby, M.N., Kutsunai, S.Y., Ackerman, S., Tzagoloff, A. & Edwards, P.A. (1992) COQ2 is a candidate for the structural gene encoding *para*-hydroxybenzoate:polyprenyltransferase. *J. Biol. Chem.* 267, 4128–4136.
9. Brems, D.N., Bruenger, E. & Rilling, H.C. (1981) Isolation and characterization of a photo-affinity-labelled peptide from the catalytic site of prenyltransferase. *Biochemistry* 20, 3711–3718.
10. Sandman, G. & Misawa, N. (1992) New functional assignment of the carotenogenic genes *crtB* and *crtE* with constructs of these genes from *Erwinia* species. *FEMS Microbiol. Lett.* 90, 253–258.
11. Math, S.K., Hearst, J.E. & Poulter, C.D. (1992) The *crtE* gene in *Erwinia herbicola* encodes geranylgeranyl diphosphate synthase. *Proc. Natl. Acad. Sci. U.S.A.* 89, 6761–6764.

12. Holloway, P.W. & Popják, G. (1967) The purification of 3,3-dimethylallyl- and geranyltransferase and of isopentenyl pyrophosphate isomerase from pig liver. *Biochim. J.* **104**, 57-70.
13. Barnard, G.F. & Popják, G. (1981) Human liver prenyltransferase and its characterization. *Biochim. Biophys. Acta* **661**, 87-99.
14. Yoshida, I., Koyama, T. & Ogura, K. (1989) Protection of hexaprenyl-diphosphate synthase of *Micrococcus luteus* B-P 26 against inactivation by sulphhydryl reagents and arginine-specific reagents. *Biochim. Biophys. Acta* **995**, 138-143.
15. Koyama, T., Saito, Y., Ogura, K. & Seto, S. (1977) Two forms of farnesyl pyrophosphate synthetase from hog liver. *J. Biochem. (Tokyo)* **82**, 1585-1590.
16. Yeh, L.-S. & Rilling, H.C. (1977) Purification and properties of pig liver prenyltransferase: Interconvertible forms of the enzyme. *Arch. Biochem. Biophys.* **183**, 718-725.
17. Barnard, G.F., Langton, B. & Popják, G. (1978) Pseudo-isoenzyme forms of liver prenyl transferase. *Biochem. Biophys. Res. Commun.* **85**, 1097-1103.